

TE PARI DOCKING IRON

INSTRUCTION SHEET

TE PARI

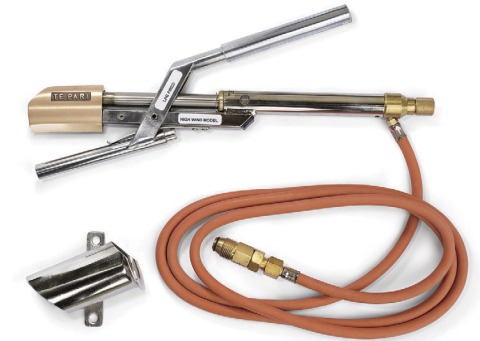

Congratulations !

Thank you for purchasing a Te Pari Docking Iron. However before using this tool please read this instruction sheet thoroughly.

For safe dependable and economical performance follow all instructions and recommendations contained herein.

FULL ONE YEAR WARRANTY

Te Pari Docking Irons are warranted for one year from date of purchase. We will repair without charge any defects due to faulty materials or workmanship.

Attached Warranty Card must be completed and mailed to Te Pari Products.

This warranty does not apply to :

- Accessories
- Damage caused where repairs have been made or attempted by others
- Damage due to misuse, neglect, wear and tear or modification.

Call us on **0800 837 274** or visit **tepari.com** for more information on our full range of animal husbandry products

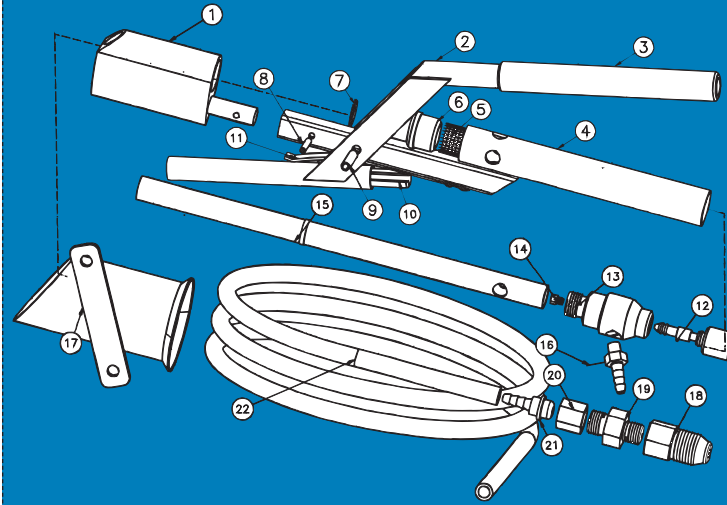

PARTS LIST

Drawing #	Standard Docking Iron	Code
1	Searing Head - High wind model	704-00019-000
1	Searing Head - Standard model	704-00018-000
2	Upper handle	704-00021-000
3	Handle grip	201-00002-000
4	Lower handle	704-00016-000
5	Gauze	102-00002-000
6	Handle bush	107-00067-000
7	Burner retaining circlip	109-00102-000
8	Roll pin - Included with searing head	
9	Roll pin - Pivot	107-00069-000
10	Roll pin - Gap adjusting	109-00189-000
11	Spring and screws	704-00029-000
12	Valve stem (tap)	704-00001-000
13	Valve body	704-00002-000
14	Jet - High wind model	704-00004-000
14	Jet - Standard model	704-00013-000
15	Burner tube (LPG) - High wind model	107-00070-000
15	Burner tube (LPG) - Standard model	107-00071-000
17	Holder - High wind model	904-00040-000
17	Holder - Standard model	904-00039-000
18	Hose fitting only 1/8 BSPT	204-00005-000
18	Adapter (Primus/POL)	107-00072-000
19	Adapter (Primus/Companion)	107-00073-000
20 (inc 21)	Hose fitting only - Comp male	204-00006-000
22	Hose only without fittings	204-00007-000
22	Hose with fittings (1/8 - Comp male)	704-00005-000

TE PARI

Warranty reply card

Te Pari Docking Iron

PLEASE COMPLETE ALL DETAILS ON THE REVERSE AND POST TO TE PARI PRODUCTS OFFICE:

Te Pari Products Ltd

NEW ZEALAND HEAD OFFICE:

PO Box 25, 9 Endeavour Crescent

Oamaru

9444

New Zealand



OPERATING INSTRUCTIONS

- Your Te Pari L.P.G. Docking Iron can be connected directly to either a primus, POL (caravan), or a companion (BBQ) type gas bottle. These 3 different fittings are all on the end of the hose. Choose the appropriate fitting and attach to gas cylinder.
Note: This unit should not be fitted with a regulator.
- Bolt the holder onto a "Y" standard or steel stake at the height you find most suitable. At the site drive the standard into the ground at a convenient spot.
- Turn the gas on at the gas bottle, then turn the tap (valve stem) on the Docking Iron to "ON" and light at the rear end of the searing head.
- Place the head of the Docking Iron into the holder, and leave for approximately five minutes to heat up.
- Before use, tune Iron with valve stem tap until flame is clear blue (not white-blue). This stops the handle heating up.
- Pick the Docking Iron up by the upper handle only and place the hot edge on the tail, grasp the bottom handle of the Docking Iron and squeeze. Cut at a rate that allows the Docking Iron to cauterize the veins. Cutting too quickly may result in bleeding. Hold by the top handle only and put the Iron back into the holder.
- When docking is complete be sure to always turn the gas off at the bottle, and then drain all the remaining gas from the hose.
- The cutting aperture can be adjusted for all different tail sizes, by tapping the large roll pin, just below the spring, either in or out, depending on the adjustments required.
- It is **important** not to let your Docking Iron get too hot, as this is more likely to result in bleeding, wastes gas, and can reduce the life of the Docking Iron Searing Head. The cutting edge of the searing head should not be allowed to become flattened. If it does, the Iron will require more effort to use, and may also result in the bending of the head assembly - run a file over the cutting edge occasionally to prevent this. It is important to keep the head clean - brush regularly with a wire brush.
- For efficient use, keep your Docking Iron clean. Store it in a bag to prevent spiders etc, putting webs into the fine intricate parts, which can cause hassles next time you use it.
- Always be careful not to point the flame from the Docking Iron toward anything that can be burnt or damaged.
- It is recommended you do not attempt major repairs yourself. Because of the intricacies of gas combustion, and the fact that not many gas service centres hold Docking Iron parts in stock, we recommend you send your Docking Iron back to the manufacturer should any problems arise.

TROUBLE SHOOTING

Problem - Iron does not get hot enough.

Remedy

- Clean inside burner tube. Insect nests or spider webs are sometimes found inside the burner tube. These restrict the gas flow and need to be cleaned out with a small rag or small brush
- Clean jet. The best way to clean a jet is by dropping it into a jar of boiling water. This removes the waxy type build-up which can occur. If unit still does not perform then replace jet (refer Parts List for correct Part No).
Jet can also be pricked with 5 amp fuse wire - **do not drill jet.**

Problem - Iron will not light

Remedy

- Ensure the gas bottle is attached correctly, has sufficient gas in it and all fittings are tightened.

Clean jet as in Remedy 2.

Problem - Iron sends a long, wavy yellow flame out the end of the Iron head.

Remedy

- Clean inside of burner tube as in Remedy 1



Call us on **0800 837 274** or visit **tepari.com** for more information on our full range of animal husbandry products

TE PARI

Warranty reply card

Te Pari Patesco Docking Iron

Please note to validate your warranty it is important to complete all applicable fields

Serial No.	Purchase Date
Name	Purchased From
Farm or trading name	
Address	
Telephone	Post Code
Email	Fax